



40 Huntingwood Drive Huntingwood NSW 2148

Phone: (02) 8825 1999 Website: www.aeroflowperformance.com

AEROFLOW PERFORMANCE COMPACT FUEL PUMP

WARNING!

THIS PRODUCT REQUIRES DETAILED KNOWLEDGE OF AUTOMOTIVE SYSTEMS. WE RECOMMEND THAT THIS INSTALLATION BE CARRIED OUT BY A QUALIFIED AUTOMOTIVE TECHNICIAN.

INTRODUCTION

Congratulations on your purchase of the Aeroflow Performance compact fuel pump. Aeroflow Performance products cannot and will not be responsible for any damage, or other conditions resulting from misapplication of the parts described herein. However, it is our intention to provide the best possible products for our customer, products that perform properly and satisfy your expectations. Should you have any questions? Please call technical support at +61 2 8825 1900 and have the product part number on hand when calling.

The Aeroflow Performance compact silver electric fuel pumps are designed for both carburettor and EFI engines, meeting most of your fuel system requirements for Street, Strip and Off-Road Vehicles. The universal rotary vane design means it is engineered for constant use, long lasting performance and quiet operation. This unique design allows the fuel to cool the internals of the pump and with no points to burn out or shaft seals that are subject to deterioration which can lead to premature failure.

The silver pump has an internal pressure-regulating valve pre-set to run 6-8 psi, and feature free-flow fuel delivery of up to 100 GPH. With female 3/8" NPT threads. Designed to handle unleaded, alcohol-based fuels and diesel.

Dimensions of this pump are 115mm height and 85mm diameter.

Each fuel pump includes an installation kit which contains the following;

1. 1 x mounting bracket
2. 3 x mounting rubber bushes
3. 3 x 1/4-20 bolts (UHL 16mm)
4. 3 x 1/4-20 nuts & washers
5. 5 x 10-32" nuts & washers
6. 2 x hose clamps
7. 2 x wiring eyelets
8. 2 x 3/8" NPT to 1/2" barb



This fuel pump is alcohol and ethanol compatible. It is recommended if installing this product with these fuels that all other components are also rated to handle this type of fuel. Ensure the fuel filter is high flow and fuel lines are correct size for the application and are designed to handle the fuel being used. Also recommended due to the alcohol fuels breaking down rubber hoses and absorbing water, too more frequently monitor, maintain and service all fuel components including fuel filters.

The factory fuel pump wiring may not be sufficient to handle the current draw of this fuel pump. Please update all wiring if necessary and add in a relay to ensure pump works correctly. If using the existing electrical plugs and wiring in vehicle ensure correct polarity is used on the new pump. If necessary, re-pin the existing one or use the included plug.

This fuel pump is only one component of your vehicles complete fuel system. Please ensure the vehicles complete fuel system is up to the task of supplying the right amount of fuel to your engine. Failure to do so may result in severe engine damage and damage to other related components.

This universal silver fuel pump should be mounted below the fuel tank and as close to the fuel tank as possible. It is recommended to also mount below the carburettor to avoid vapour lock conditions. Do not mount the fuel pump near exhaust system or extreme heat sources as this can damage the fuel pump. Ensure the fuel pump is mounted away from any sources of water.

Always install a good quality fuel filter on the inlet side of the fuel pump. This will stop any debris from entering and damaging the fuel pump. Failure to do so will void warranty.

Failure to follow any of the above may result in fuel leakage, bursting of fuel lines, poor vehicle performance and/or decreased fuel pump life.

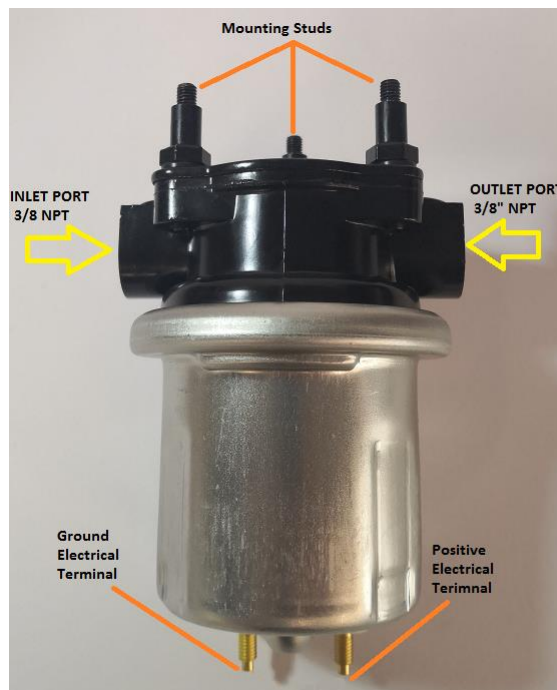

For more information or technical enquires

Contact: Aeroflow Performance on

Phone: (02) 8825 1979 Website: www.aeroflowperformance.com

Installation Guideline

Always diagnose the cause of failure before replacing any electric fuel pump

Ensure fuel tank, fuel lines and fuel filters are cleaned from debris such as dirt and dust as this may cause the pump to fail.

1. Disconnect the negative battery
2. Disconnect the old fuel lines from the fuel pump.
3. Select the best location to mount the fuel pump. Ensure it is away from extreme heat sources. Mount as close to the fuel tank as possible. Ensure to use the mounting bracket that is included.
4. Mount the fuel pump with electrical terminal pointing down towards the ground.

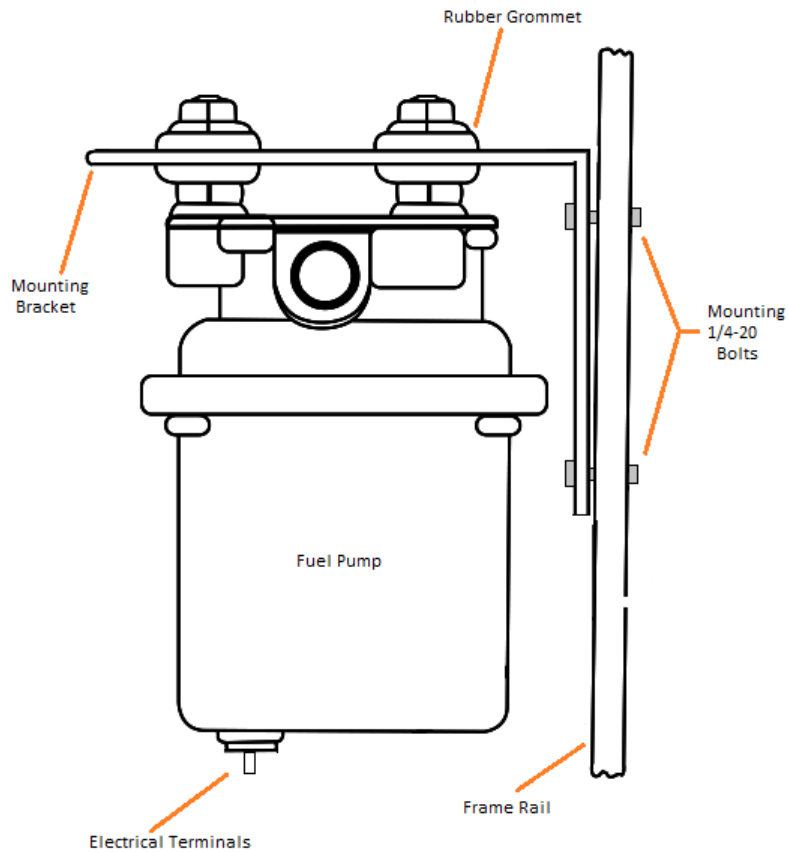

5. Using the mounting bracket as a template drill three 1/4" holes to attach the bracket. Position pump on the bracket. The "IN" port must be connected to the line running from the fuel tank.
6. Push the rubber grommets into the appropriate holes on the mounting bracket. Push the pump studs through the rubber grommet. Use a flat washer on the end of the rubber grommet. Tighten the lock washers and nuts down evenly. Press the rubber boots firmly onto the threaded post, making sure rubber boot seals around the pump studs.

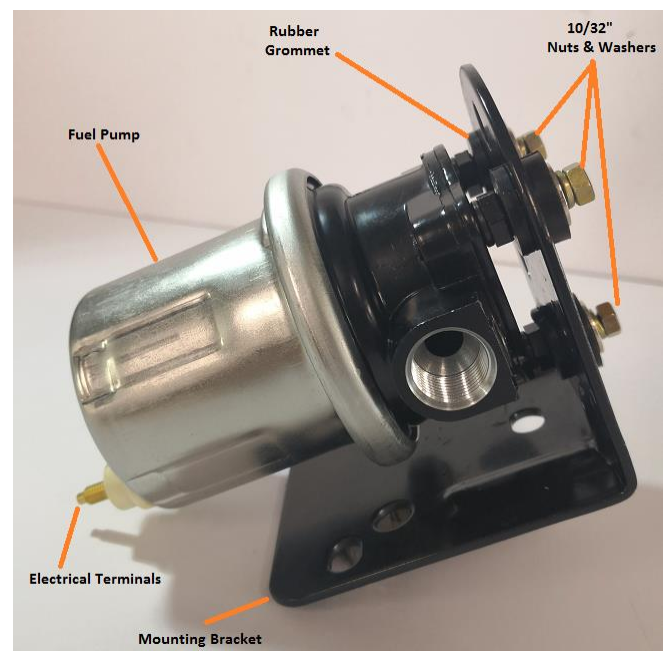

7. Install the fuel pump and mounting bracket to the desired location.
8. Install the eyelet end of the ground wire to correct polarity terminal on the fuel pump. This ground polarity must be the same as the battery ground polarity.
9. Install supplied hose fittings to each end of the fuel pump. Ensure to use the appropriate thread sealer to seal each of these fittings into the pump such as AeroSeal.
10. Connect both fuel lines to the supplied barb fittings with the worm drive hose clamps. The inlet side of the pump should be connected to your fuel line coming from the fuel tank. The outlet side of the pump should be connected the fuel line that goes to the engine bay to feed fuel.

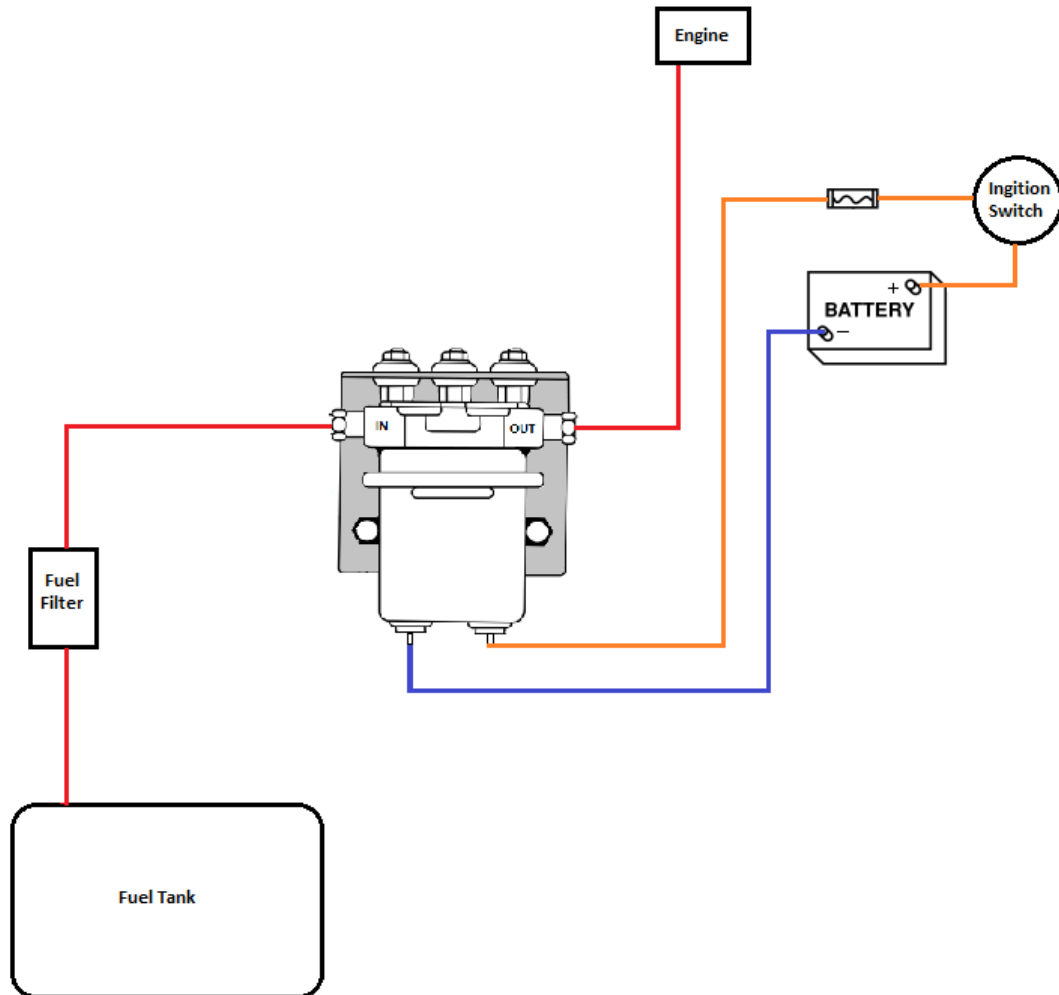

11. Install the eyelet end of the supplied wiring to the positive polarity terminal on the fuel pump. Wire this to the correct wiring source such as a relay, fuel or ignition switch.
12. Start engine and test for leaks.

For more information or technical enquires

Contact: Aeroflow Performance on

Phone: (02) 8825 1979 Website: www.aeroflowperformance.com